

## SERIES P8721-000-R

### Single Axis Position Controller

- integrated relay outputs
- integrated mains power supply
- 3 different speed rates
- manual operation mode
- single set operation
- 200 sets program memory



<b>1. SHORT DESCRIPTION</b>	<b>4</b>
<b>2. FUNCTIONS</b>	<b>4</b>
2.1 Two speed operation	4
2.2 Three speed operation	5
2.3 Setting Datum/Reference	5
2.4 Encoder Monitoring	5
2.5 Quantity Counter	6
2.6 Program counter	6
2.7 Fault Monitoring	7
<b>3. FRONT PANEL</b>	<b>8</b>
3.1 Functions of Display	8
3.2 Functions of LED's	8
3.3 Function of the Keypad	9
<b>4. OPERATION MODES</b>	<b>11</b>
4.1 Manual mode	11
4.2 Single set operation	11
4.3 Program Operation (R8/4 = 0)	12
4.3.1 Selection of a Program Block	12
4.3.2 Input of a Program	12
4.4 Table mode (R8/4 =1)	13
4.4.1 Operation in Table mode	13
<b>5. REGISTER INPUT</b>	<b>13</b>
5.1 Unlocking Registers by Security Code	13
5.2 Setting and Changing Register Values	14
5.3 Locking of Registers	14
<b>6. PARAMETER TABLE</b>	<b>15</b>
<b>7. DESCRIPTION OF REGISTERS</b>	<b>16</b>

<b>8. RELAY CONFIGURATIONS</b>	<b>25</b>
<b>9. FUNCTIONS OF INPUTS (TERMINALS ST3 AN ST4)</b>	<b>27</b>
<b>10. FUNCTIONS OF OUTPUTS TERMINALS ST5 &amp; 6</b>	<b>29</b>
<b>11. CONNECTIONS</b>	<b>30</b>
11.1 Terminal assignment	31
<b>12. TECHNICAL SPECIFICATIONS</b>	<b>31</b>
<b>13. INSTALLATION/WIRING</b>	<b>32</b>
<b>14. ONLY FOR SERVICE</b>	<b>33</b>
<b>15. TYPE DESIGNATION</b>	<b>34</b>
<b>16. LIABILITY EXCLUSION / GUARANTEE</b>	<b>35</b>

## 1. Short Description

### Features of P8721

- 2 or 3 speed positioning
- absolute and incremental positioning modes
- program memory (200 sets)
- single set operation
- manual operation, slow and fast mode
- batch counter with zero-output
- pulse factor
- datum setting routines
- tool offset compensation in incremental mode
- Incremental error compensation
- backlash compensation
- tolerance window
- encoder monitoring
- max. input frequency 20 kHz

The unit is suitable for operation with any type of 2 or 3 speed bi-directional drive or any variable speed drive with 1, 2 or 4 quadrant of control. The performance and accuracy obtained is dependent on the type of drive chosen. The outputs for stepped speed drives are relays. These outputs can be configured in a number of ways to suit all types of control circuits. Actual position is monitored by incremental encoder. The power supply unit is integrated. The controller can be used to position machinery to any desired absolute position. Alternatively, the controller can be used to feed material through a process.

#### Notice!

The integrated **.R** unit contains only **10** relays and cannot provide the Auxiliary functions. If Auxiliary functions are required, the purchase then non-.R version, with external relays.

## 2. Functions

### 2.1 Two speed operation

NB:  $R1 = R2 > R3$  The value in Register 1 must be the same value as R2

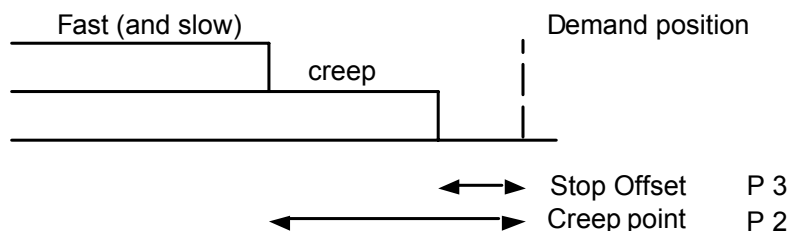

## 2.2 Three speed operation

NB:  $R1 > R2 > R3$

The value in Register 1 must be larger than R2

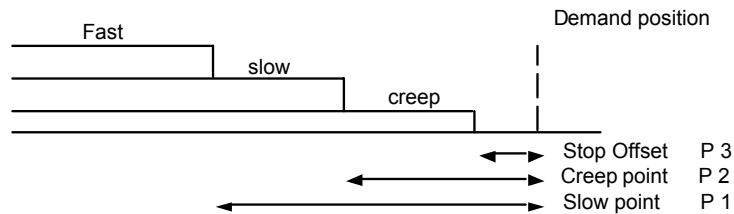

**NB:** The stop offset is only effective when  $R8 = 1xxxxx$ .

## 2.3 Setting Datum/Reference

Datum can be set in a variety of ways. The method is selected in Register R8/3

**R8 = xx0xxx** Datum to R7  
Closing input St 3 / 4 transfers the value set in R7 into Actual Value Display

**R8 = xx1xxx** Setting to Preset  
Closing input St 3 / 4 transfers the Demand display value into Actual Value Display

**R8 = xx2xxx** Automatic reference + (positive direction)

**R8 = xx3xxx** Automatic reference – (negative direction)

**R8 = xx4xxx** Datum with keypad alone  
The value of R7 is transferred to Actual Display by accessing R7, typing in value and then pressing E.

## 2.4 Encoder Monitoring

If, after positioning is activated, no Encoder pulses are received after a time set in R19 (0.1 to 9.9 sec), positioning will be aborted and fault 01 will be displayed. Setting R19 to 0.0 sec, disables this feature.

## 2.5 Quantity Counter

Register R18/6 sets the method of counting whether adding or subtracting

<b>R18 = xxxxx1</b>	<b>Automatic subtracting</b>
<b>R18 = xxxxx2</b>	<b>Automatic adding</b>
<b>R18 = xxxxx3</b>	<b>Manual subtracting (external input signal)</b>
<b>R18 = xxxxx4</b>	<b>Manual adding (external input signal)</b>
<b>R18 = xxxxx5</b>	<b>Automatic add/subtract (Single only)</b>
<b>R18 = xxxxx6</b>	<b>Manual add/subtract (Single only)</b>
<b>R18 = xxxxx7</b>	<b>Manual subtracting STOP when ZERO</b>
<b>R18 = xxxxx8</b>	<b>Automatic subtracting STOP when ZERO</b>

With adding function, the counter starts from zero.

When the set quantity is reached, the quantity complete output will be pulsed.

With subtracting function, counting from preset to zero takes place. When zero is reached, the quantity complete output will be pulsed.

With add/subtract function, subtracting will take place if a preset value is entered. On reaching zero, adding will ensue. When the quantity counter goes from 1 to 0, a pulse output is given.

The length of this pulse is set in P11. Setting 0.0 gives a maintained output.

## 2.6 Program counter

The program counter will be active when **R46** > 0.

**R 47** will be incremented after a complete program-operation. If **R47** >= **R46**, a message „Count“ is shown in the actual-value-window (after program-operation) and the counting value (**R47**) is shown in the Target-value-window.

Simultaneously with this message the output **ST5Pin8** will be activated.

If **R48** = 0 the output works "static". If **R48** > 0 the output will be reset after selected pulse-time in **R48**.

The message (display and output **ST5Pin8**) will be cleared after pressing any key (also when time in **R48** not ran off). In **R47**, the counter value can be deleted respective set to a new value.

Parameter:

<b>R46</b> PCC-Limit	- releases when reached	(Access always possible)
<b>R47</b> PCC-Counter	- value	(Access always possible)
<b>R48</b> PCC-Timer	- for output-signal	(Access protected by <b>R98</b> )

## 2.7 Fault Monitoring

When a fault occurs, it's number flashes in Actual Value Display

Fault number	<b>01</b>	=	Encoder
	<b>02</b>	=	End Limit minimum
	<b>03</b>	=	End Limit maximum
	<b>04</b>	=	Actual position < min software limit (R13) Hand Target position < min software limit (R13) Single
	<b>05</b>	=	Actual position > max software limit (R14) Hand Target position > max software limit (R14) Single
	* <b>07</b>	=	External stop activated or wire break

\*The fault message is cleared by pressing any button.

"07" also flashes if "Stop" on front panel is activated in middle of any move.

**\*Notice for 07:** The external stop input must be linked before system can operate. Therefore, if external n/c pushbutton is not fitted, then insert a permanent wire link.

### 3. Front panel

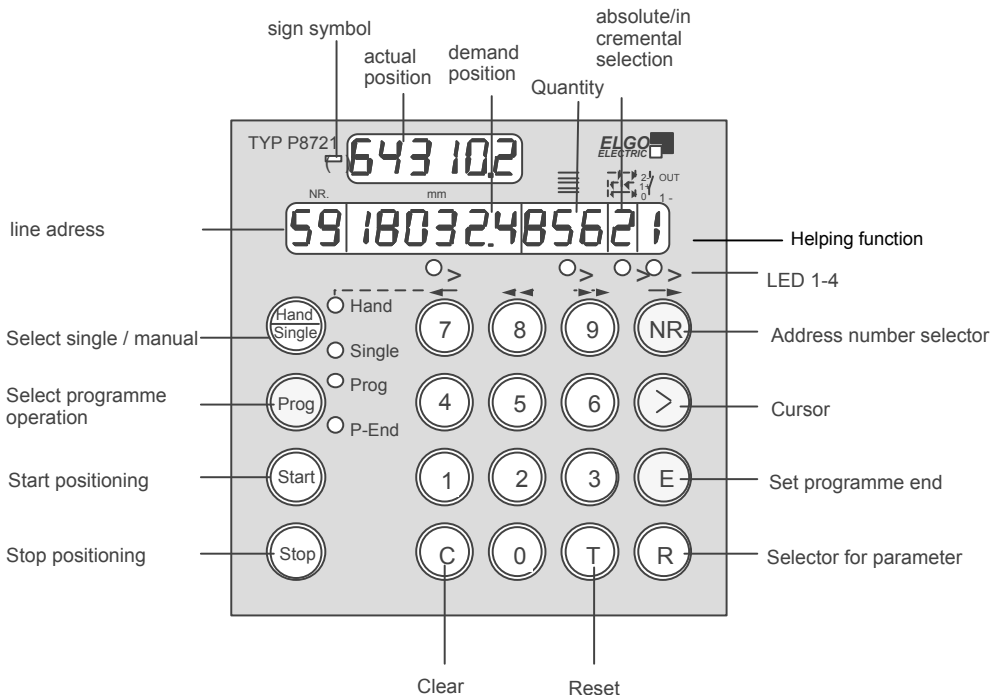

#### 3.1 Functions of Display

- Address Window : Shows address line of Program (or Register Nr)
- Actual Position : Shows the Actual Position of the axis
- Demand Position : Here you can enter the required position (or Register value)
- Quantity Window : Shows how many pieces are left to be cut (or have been cut) or how many incremental moves yet to be completed.
- Abs/Incr Window : Defines Target window
  - 0 = Absolute dimension
  - 1 = Incremental + positive direction
  - 2 = Incremental - negative direction
  - 3 = Incremental from zero
  - 4 = Incremental from zero – tool offset

#### 3.2 Functions of LED's

- LED "Hand" : Illuminates after selecting "Single" mode by "Hand/Single" button
- LED "Single" : Illuminates after selecting "Hand" mode by "Hand/Single" button
- LED "Prog" : Illuminates when "Program" mode is selected.
- LED "P-End" : Illuminates when program operation is complete (program end)
- LED 1 - 4 : Indicate which input window is selected. Windows can be changed by button >

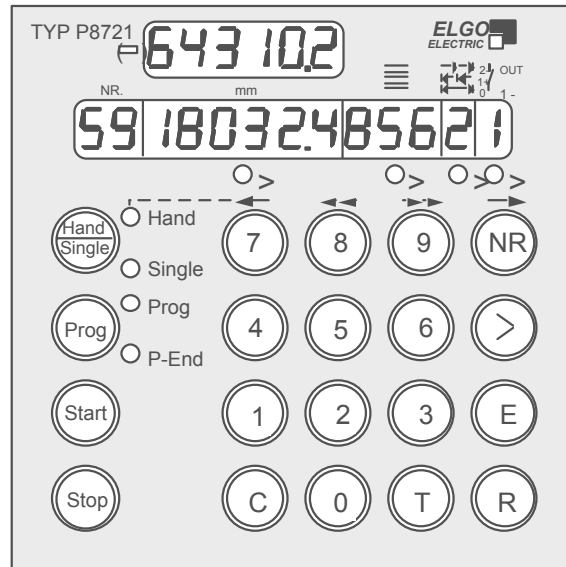

### 3.3 Function of the Keypad

#### Hand/Single

1. Alternate pressing will select "Single".  
A Demand position can be entered. Using Cursor > Button enables quantity to also be set.
2. Alternate pressing will select "Hand".  
The Buttons 7/8/9/NR can be used for manual positioning at fast and creep speeds in both directions.

**Prog** Selects Program mode.  
Execute the desired program by pressing "Start".  
(or Press R, to access Registers)

**Start** Starts positioning action  
The Start Button is inhibited when programming or setting of Registers is selected – also in Hand mode.

**Stop** Motion is stopped.

**NR** This Button is only active in Program mode. It has the following functions.

1. Start the programming action. Thereafter, only the Cursor Button > needs pressing
2. Checks existing program. Pressing "NR" repeatedly scrolls through the program.
3. Selects the required address in Table mode (see section 4.3).

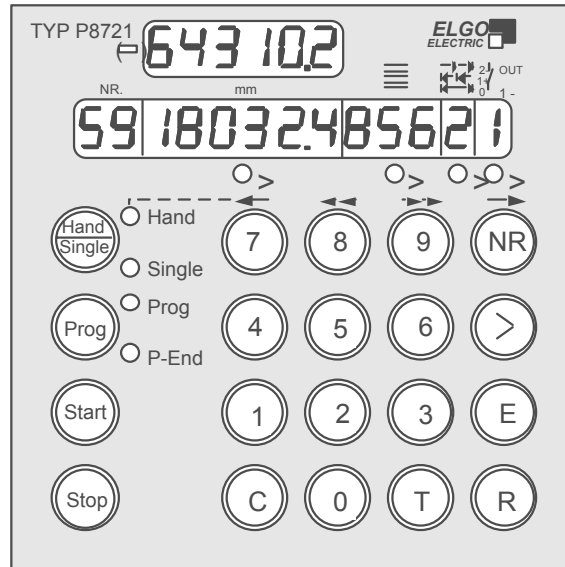

- > The Cursor Button selects the Target windows sequentially.  
On completion of a line, the next press of ">" will select the next Address line.  
**LEDs 1 – 4** indicate the selected Window.
- E** This Button will :
  - Set the end of program and reset the controller into operation mode.  
This Button should be pressed only when the last window is selected (LED3)
  - Stop the entered Register values.
  - End Register setting at any point.
- R** Selector for entry of Register values. Only active when "Prog" selected.
- T** Reset Button : Resets all Target windows to zero in Program mode.
- C** Clears selected Target window value.
- 0 – 9** Numerical keys for data entry.

## 4. Operation modes

Switch on conditions are programmable in register **R33**:

**R33 = xxxxx 0** same conditions as at time of switch off  
**R33 = xxxxx 1** Single mode  
**R33 = xxxxx 2** Program mode  
**R33 = xxxxx 3** Hand mode

The Actual position is memorised. In "Hand" the target window line is switched off.

In "Prog" mode the Target windows are set to zero.

In "Single" the Demand value is set to zero.

### 4.1 Manual mode

#### Press T

Resets target windows to zero. Use the Button "Hand/Single" to select "Hand". LED "Hand" illuminates.

Buttons **7/8/9/NR** can be used to move the Axis forward and backwards at high and low speeds (whilst the button is depressed). The remaining Buttons are inhibited in Manual mode.

The Buttons have the following functions :

- Button **7** Slow Reverse
- Button **8** Fast Reverse
- Button **9** Fast Forwards
- Button **NR** Slow Forwards

If a 3 speed drive is used, the Fast and Creep speeds are used.

Physical direction of movement can be reversed by setting of Register R64.

### 4.2 Single set operation

In addition to Program operation, a Single complete line can be set.

The activated windows can be selected in parameter R28/2

<b>Press Hand/Single</b>	LED "Single" is illuminated.
<b>Use Keys 0 – 9</b>	To enter desired position.
<b>Press &gt;</b>	LED under Quantity Window illuminates.
<b>Use Keys 0 – 9</b>	To enter desired quantity.
<b>Press &gt;</b>	If further windows are activated cursor LED move to next window
<b>Press Start</b>	The Axis moves to required position.

## 4.3 Program Operation (R8/4 = 0)

### 4.3.1 Selection of a Program Block

The P8721 has a Program memory of 200 Address lines. These can be divided into several Blocks of **equal** quantity of lines (see Register R41). Each Block can store a different Program, which can be selected for operation, at will. If for example, 8 Blocks of 25 Lines is set, selecting a Block higher than 8, will result in Block 8 being selected.

To select the required Block for operation.

<b>Press Prog</b>	Selects Program mode
<b>Press T</b>	Resets windows to zero
<b>Press R</b>	The Nr (Address) Window flashes
<b>Key in 40</b>	40 appears in Nr Window (flashing).
<b>Press &gt;</b>	The previously selected Program Block is displayed in Target window
<b>Press C</b>	Clears value to zero
<b>Key in (e.g.) 3</b>	3 appears in Target window
<b>Press E</b>	Program Block 3 is called up and sequence is ended Controller returns to Operation mode (all input windows are "0")

Now the Block can be used with the existing program, or a new program can be entered.

### 4.3.2 Input of a Program

The required Program Block is selected in accordance with section 4.2.1. The Memory-block remain selected also after power down.

<b>Press Prog</b>	Selects Program mode
<b>Press T</b>	Reset controller.
<b>Press Nr</b>	"01" appears in Nr Window. LED illuminates under Target window.
<b>Press C</b>	Clears existing value.
<b>Use Keys 0 – 9</b>	To enter new dimension.
<b>Press &gt;</b>	LED illuminates under Quantity Window.
<b>Press C</b>	Clears existing value.
<b>Use Keys 0 – 9</b>	To enter required quantity.
<b>Press &gt;</b>	LED illuminates under Abs/Incr Window
<b>Press C</b>	Clears existing value.
<b>Press : 0</b>	= Absolute Position
<b>1</b>	= Incremental + positive direction
<b>2</b>	= Incremental – negative direction
<b>3</b>	= Incremental from "zero"
<b>4</b>	= Incremental from "zero" – tool offset value

Now one program line is completed.

The operator can now end programming or continue to next Address line.

To end programming – **Press E**  
To move to next line - **Press >**

#### 4.4 Table mode (R8/4 =1)

If R8/4 is set to 1, then the controller operates in 99 selectable address Table mode. Programming is exactly the same as in 4.2.2.

##### 4.4.1 Operation in Table mode

An address line of the stored program can be called up and positioning effected to that setting.

<b>Press Prog</b>	Selects Program mode
<b>Press T</b>	Resets Controller.
<b>Press Nr</b>	The Nr Window flashes "0".
<b>Key in (say) 58</b>	"58" flashes in Nr Window.
<b>Press &gt;</b>	The programmed values of address <b>58</b> are displayed.
<b>Press Start</b>	The Axis executes the demanded settings.

## 5. Register Input

### 5.1 Unlocking Registers by Security Code

The values of Registers R1 to R97 can be changed after the Security Code 250565 has been entered into Register R98. (Note that Registers R06, R07 and R40 are **accessible** without need for Security Code). Accessing Registers can only take place when Controller is selected to Program mode. In Register input mode, the decimal point is always at the correct position for the register resolution. All Registers are entered in the Position Target window.

Use Button **E** to :

- a) Store Register values
- b) End editing at any point.

<b>Press Prog</b>	Controller is set to Program mode. LED "Prog" illuminates.
<b>Press R</b>	The Nr Window flashes
<b>Key in "98"</b>	Value 98 appears in Nr Window with "8" flashing.
<b>Press &gt;</b>	The Target window shows "000000" without decimal point.
<b>Press C</b>	Clears display to zero.
<b>Key in "250565"</b>	Display shows 250565 (The Security Code).
<b>Press E</b>	The Controller is now set to data entry mode. All Windows are set to zero. Decimal point is reinstated.

## 5.2 Setting and Changing Register Values

**Example:** The Slowdown Point of 20.0 mm needs to be entered.

Assuming that Registers have been unlocked as above :-

<b>Press R</b>	The Nr Window flashes.
<b>Press 1</b>	1 (flashing) is displayed in Nr Window ie Register 01.
<b>Press &gt;</b>	The existing value of R01 is displayed in Target window Decimal point is extinguished.
<b>Press C</b>	Clears old value to zero.
<b>Key in "200"</b>	Window shows 200 (ie 20.0 mm).
<b>Press E</b>	The new value is memorised. All Windows are reset to zero and Decimal Point is reinstated.

Any Register from 1 to 97 can be selected and changed in the above manner. If sequential Registers are to be set, Press > twice instead of E and continue editing Register by Register.  
Press E on completion.

It is possible to run the Controller with Registers unlocked, e.g. having set the Stop offset Register R03, you may now execute a "Single" move and then go back to edit R03.

## 5.3 Locking of Registers

Once all the values have been set, it is necessary to relock the Registers to avoid accidental changes. There are three methods to do so.

- Select "R98" and type in (instead of security code) a "0" by the "C" button:  
Type in : **R - 9 - 8 - > - C - E**
- Activate the "Reset" input
- Switch "power down" and shortly after "power on"

## 6. Parameter table

Register	Function	Adjustment-Range	Default	Customer
01	Slow speed distance (forward)	0.1 mm	200*	
02	Creep speed distance (forward)	0.1 mm	100*	
03	Correction stop (forward)	0.1 mm	0	
04	Spindle compensation	0.1 mm	50	
05	Retract distance	0.1 mm	500	
06*	Tool Width /Tool offset	0.1 mm	0	
07*	Datum/reference value	0.1 m	1000	
08	System Register 1	See Page 17	130000	
09	Position reached pulse	0.1 s	10(0=held)	
10	Backlash dwell time	0.1 s	10	
11	Quantity reached pulse	0.1 s	10(0=held)	
12	Tolerance window	0.1 mm	0	
13	Min software limit	0.1 mm	0	
14	Max software limit	0.1 mm	500000	
15	Software limit disable	0,1,2,3	0	
17	Display brightness	0-15	10	
18	System Register 2	See Page 20	000001	
19	Encoder pulse monitor time	0.1 s	0	
20	Decimal point	3,0,2,1	0	
21	Slow speed distance (only backwards)	0.1 mm	200*	
22	Creep speed distance (only backwards)	0.1 mm	100*	
23	Correction stop (only backwards)	0.1 mm	0	
24	Window "forced loop"	0,1mm	0	
25	Home position	0,1mm	10000	
28	System Register 3	See Page 22	000000	
29	Time delay for drive enable	0.1 sec	10	
30	Time "Program-end"	0.1 s	10	
31	Closed loop inhibit time in Hand	0,1 sec	10	
33	Power on mode	0,1 sec	10	
34	Start delay time	0,1 sec	10	
40*	Program Block selection	See Page 12	1	
41	Number of lines in Prog Block	1 – 99	20	
46*	Program counter Limit	1-99	0	
47*	Program cycle counter	0 - 9999	0	
48	Program Counter timer (pulse time)	0 - 9999	0	
56	Encoder edge multiplier	1,2,4	1	
64	Direction of manual buttons	0-1	0	
69	Speed of automatic reference run	0-2	0	
88	System Register 4	See Page 24	000000	
90	Button enable in service mode	0,1,2	0	
94	Inch / factor multiplier	0.0to 9.99999	100000	
96	Pulse factor for encoder		100000	
97	Inch / mm conversion mode	0,1,2,3	0	
98	Security code	250565	0	
99	Service	- -	0	

\* Logical sequence values such as these must always be present, regardless whether 3 speed, 2 speed or 1 speed drive is used.

P1 > P2 > P3 for 3 speed drive P1 = P2 > P3 for 2 speed or 1 speed drive.

Registers R6, R7 R40, R46 and R47 can be accessed and changed without need for Security Code.

The Registers R50 to 55, 57 to 63 and 65 to 68 are for analogue output only.

## 7. Description of Registers

- R01** Slow speed distance forward/reverse or forward only ( see R28/2). Distance at which the controller switches from high speed to slow speed. The output high speed will be switched off.
- R02** Creep speed distance forward/reverse or forward only ( see R28/2). Distance to demand position at which the controller switches from slow to creep speed
- R03** Stop offset distance forward/reverse or forward only ( see R28/2)

The overrun distance can be programmed to compensate for distance from the switch-off point of the motor to standstill. For exact positioning, the overrun distance should be very small (0.0 to 0.5 mm). Therefore the mechanical friction should be steady and the creep speed should be very slow.

During commissioning, first set R12 to zero (to eliminate Tolerance window blanking), then set the value of R03 to 0.0 and execute a number of moves in both directions. Note the average overrun distance and then set R03 to that value. Then set R12 to suit.

### **R04 Spindle compensation**

To correct for screw or pinion backlash, the Demand position should be approached from one direction only. In positive direction therefore, the Demand position will be overrun by the value of R4 and driven back at creep speed after a time delay of R10, to the Demand position.

### **R05 Retract distance**

There are different modes available in the P8721, selectable by Register R18/2.

If R18/2 = 0    Retract Position = Actual + R5

If R18/2 = 1    Retract Position = Value of R5

Whilst the input St3/6 is held on, the slide will move to the "Retract" position. On release of input, slide will return to the original position. (Value 0)

When input St3/6 is activated, the slide moves to position as set in R5 but will not return to original position on release of input. (Value 1)

### **R06 Tool offset compensation**

This Register can be accessed without Security Code. When moving in incremental, it is often the case that the subsequent function is a cut that removes part of the material. Thus to cut the correct preset lengths, it is necessary to move the demanded distance plus the "Tool Offset". This feature is active in incremental mode.

### **R07 Datum/reference value**

The Datum value is stored in this Register. The value is used in different ways, in accordance with setting of P8/3. Input St3/4 initiates loading. This Register can be accessed without Security Code.

## R08 System Register 1

This Register sets the basic operating functions of the unit.

### Target window

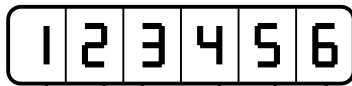

#### Spindle compensation

- 0 = no spindle compensation
- 1 = negative spindle compensation
- 2 = positive spindle compensation
- 3 = negative spindle compensation with forced loop (R24)
- 4 = positive spindle compensation with forced loop (R24)
- 5 = negative spindle compensation with backlash
- 6 = positive spindle compensation with backlash

#### Relay output configuration

- 0 = 3 speed operation
- 1 = Forwards + Backwards
- 2 = 2 speed Run + Reverse
- 3 = 2 speed separate output operation
- 4 = Fast only in reverse
- 5 = 3 speed Binary coded
- 6 = 3 speed operation forwards + backwards

#### Program Memory

- 0 = Program line operation mode
- 1 = Table operation mode

#### Datum/reference

- 0 = Datum to R7 with external pulse by key-switch
- 1 = Datum to the target value window with external key-switch
- 2 = Reference run +
- 3 = Reference run -
- 4 = Datum to R7 by key-board only

#### Display windows (program mode only)\*

- 0 = All windows in use
- 1 = Target alone
- 2 = Target + Batch counter
- 3 = Target + Batch counter + Abs/Incr.

#### Type of positioning

- 0 = Analogue positioning
- 1 = Fast/slow/stop mode

\* Display selection for single mode see R28/6 (page 22)

**R09 Time position reached**

At the end of each move, the controller gives an output, to signal "in position". The length of this pulse is set in R9. Setting 0.0 gives a maintained output. This output St5/1-2 is active when Actual position = Demand position +/- Tolerance window R12

**R10 Backlash dwell time**

When the machine stops at the end of the overrun, it is usually desirable to have a short delay. The time is set in this Register.

**R11 Time "Quantity complete"**

When the quantity counter goes from 1 to 0, a pulse output at St6/3-4 is given. The time this will be set in R11. Setting 0.0 gives a maintained output.

**R12 Tolerance window**

It is possible to enter a value in Register R12 that represents an acceptable tolerance e.g. 0.1 mm. When the Actual Position is within the Tolerance window, the Actual position displayed is made equal to the Demand position. The actual error is not lost, as the controller knows the true position.

Example: R12 = 0.2 Therefore tolerance window is +/- 0.2mm

**Display without tolerance      Display with tolerance**

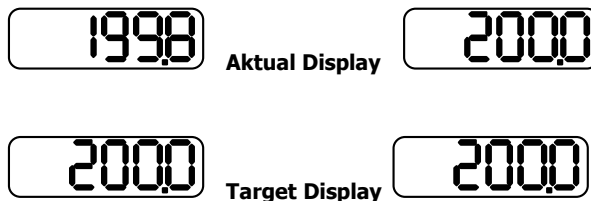

**Notice: The tolerance window "R12" should be "ZERO" at first start up!**

**Single set operation**

Immediately after start signal, the controller checks the software limits. If the Demand position is greater or smaller than the corresponding limit, the controller will stop and show the error message on the display. The backlash distance in R4 is considered at the check of the Max software limit, if the backlash is activated in R8/6.

**Manual operation**

The movement will stop when software limits are reached. If moving at high speed, the drive will drop to creep speed at a distance set in R1 from this limit. This prevents running into the ends of the machine. The end limit values are modified by backlash value as set in R4, if R8/6 is selected.

## R15 Software Limit / End Limits Selection

Software limits (R13 & R14) are active in accordance with the setting of R15/6

<b>R13/R14 Min/Max software limits</b>	
	Fault Message
Target < Limit R13	= <b>04</b>
Target > Limit R14	= <b>05</b>

- xxxxx0** Both software limits active
- xxxxx1** Min software limit (R13) inhibited
- xxxxx2** Max software limit (R14) inhibited
- xxxxx3** Both software limits (R13&R14) inhibited

External limit switches can be connected to the St4/3 (backwards) and at St4/4 (forwards)

- xxxx0x** Both limits inputs active
- xxxx1x** Min limit input (St4/3) inhibited
- xxxx2x** Max limit input (St4/4) inhibited
- xxxx3x** Both software limit inputs (St4/3 St4/4) inhibited

**Notice: If these are not connected to limit switches they need to be connected Normally closed (i.e. linked out).**

## R17 Display brightness

With the setting of this Parameter, the brightness of the displays can be altered.  
0= dark, 15 = max brightness.

## R18 System Register 2

This Register also sets the functions of the controller.

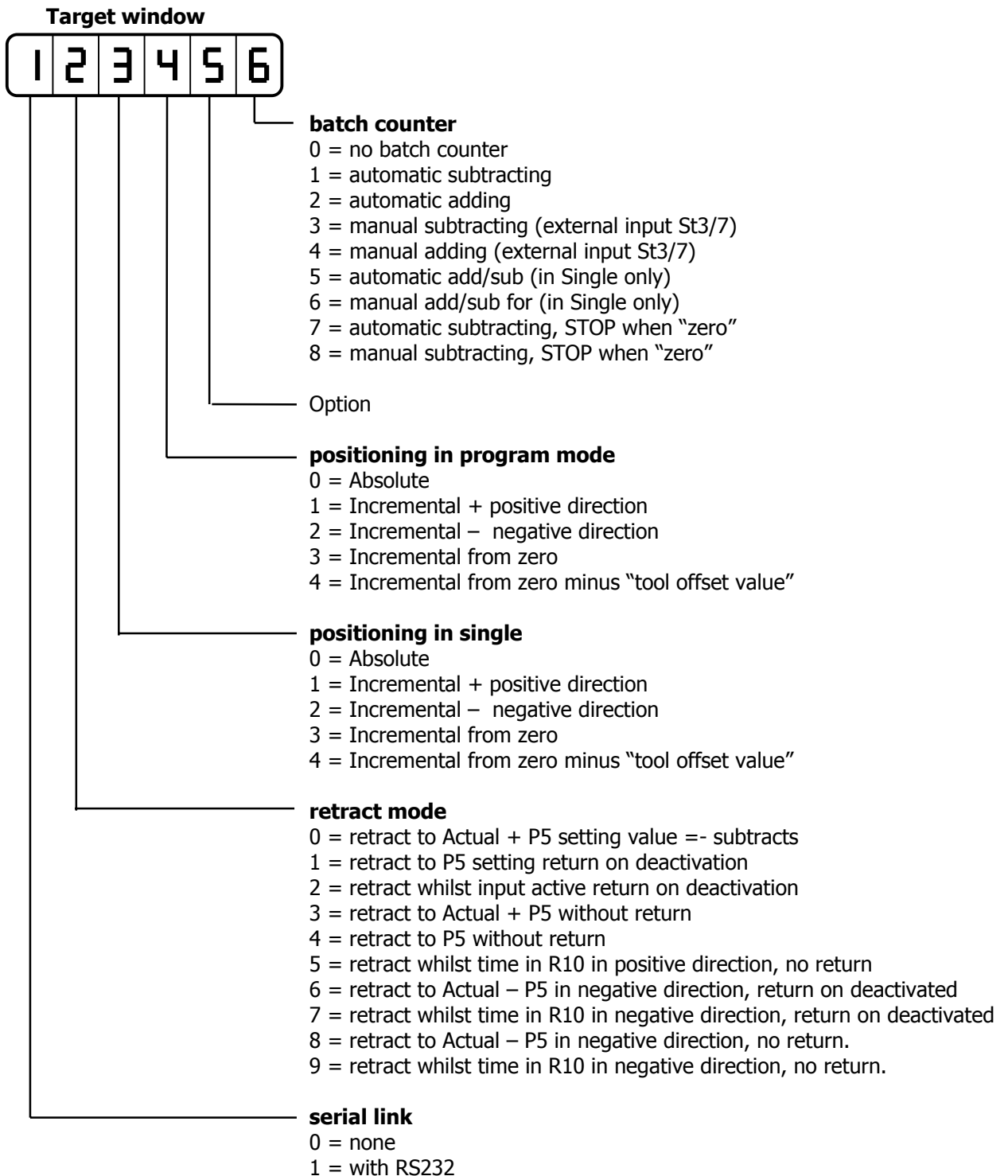

### R19 Encoder monitoring

If after positioning is initiated, no Encoder pulses are sensed after a time set in R19, positioning will be aborted and Fault 01 will be displayed. Setting R19 to 0.0, disables Encoder pulse monitoring.

### R20 Decimal Point

The decimal point is placed in a fixed position and is optical only. It does not change the resolution of the system. The position is dependent on setting of Register R97.

With R97 = **xxxxx0** = mm mode  
 R20 = **xxxxx0** = 1/10  
 R20 = **xxxxx1** = 1/1000  
 R20 = **xxxxx2** = 1/100  
 R20 = **xxxxx3** = without

With R97 = **xxxxx1** = Inch mode 1/100  
 Decimal point is fixed at 1/100

With R97 = **xxxxx2** = Inch mode 1/1000  
 Decimal point is fixed at 1/1000

With R97 = **xxxxx3** = "Inch" factor freely programmable in R94  
 R20 = **xxxx0x** = 1/10                      R20 = **xxxx1x** = 1/1000  
 R20 = **xxxx2x** = 1/100                     R20 = **xxxx3x** = without

### R21 Slow speed distance in negative direction

This parameter is important for application with different load conditions on forward or backward if no use of automatic backlash compensation is desired. The Parameter R28/2 has to be set to 1 for activation. Distance at which the controller switches from high speed to slow speed in negative direction (. The output high speed will be switched off.

### R22 Creep speed distance in negative direction

Distance to demand position in negative direction can be set in this parameter at which the controller switches from slow to creep speed

### R23 Stop offset distance in negative direction

The overrun distance in negative direction can be programmed in this parameter to compensate for distance from the switch-off point of the motor to standstill.

### R24 Backlash overrun zone 2

If actual position is inside the range of this register, at Start there is executed a backlash operation.

### R25 Home Position

Activating the input St3/5 will send the Axis to a prefixed position as set in R25.

## R28 System Register 3

This Register also sets the functions of the controller.

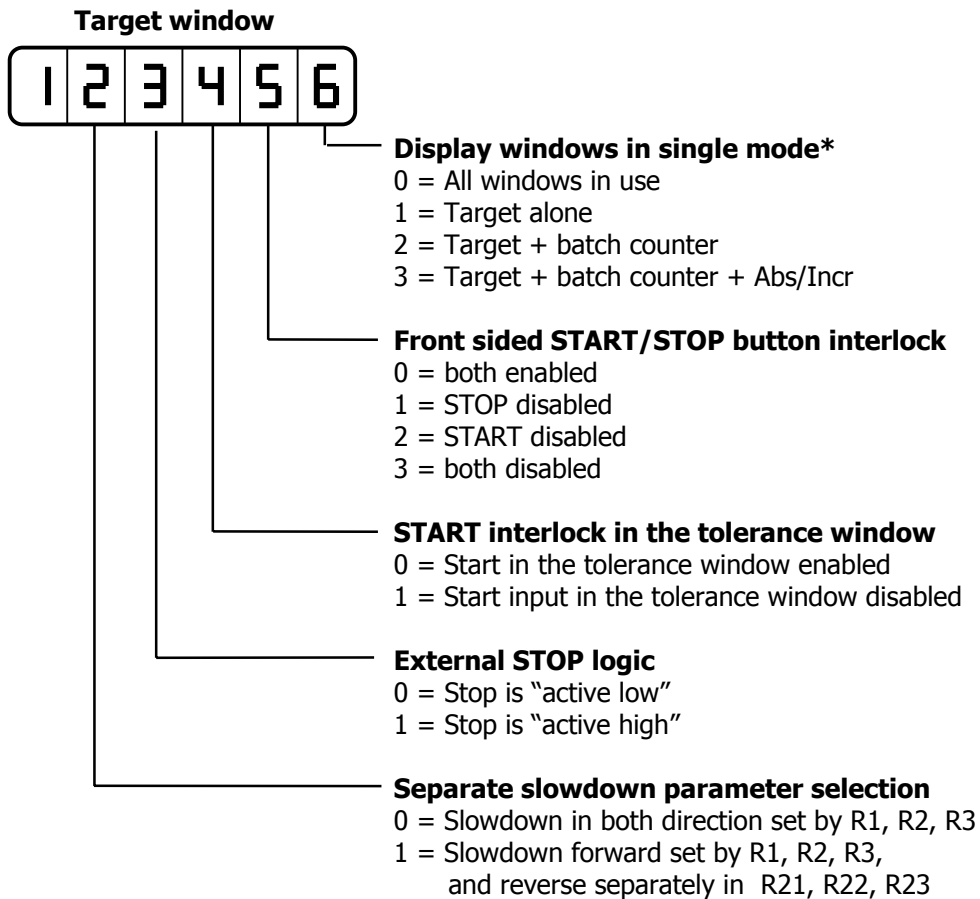

\* Display selection for program mode see R8/2 (page 16)

## R29 Time Delay for Drive inhibit (Positioning)

On activating start, output St6/1-2 is activated. On arriving in position, after a time delay of R29 this output deactivates.

## R33 Controller switch on mode

The value set in this register will determine the mode of operation that the controller assumes on power up

**Value 0 - same as power off**  
**Value 1 - single mode**  
**Value 2 - program**  
**Value 3 - Hand**

## R34 Start delay time

On activating start, the controller calculate the parameters to arrive in position, after a time delay of this Parameter the controller start the analogue output.

## R40 Program Block selection

This Register can be accessed without opening Security Code in R98. The Program Block required for operation should be entered.

**R41 Number of Lines in each Program Block**

Enter the number of lines required per Program Block (1 – 99). The number of Blocks will be calculated automatically.

**Example :**  
 Total number of Lines = 200  
 Number of Lines required per Block = 25 (enter 25 into R41).  
 Therefore the number of program blocks = 8

An entry of Lines over 99 will result in an error message "08" to flash.

**R46 Program cycle pre-selection**

This Register can be accessed without opening security code in R98. The number of program executions can be entered in this register.

**R47 Program cycle counter**

This Register can be accessed without opening security code in R98. The actual count value can be displayed and set in this parameter.

**R48 Output Program cycle complete time**

The length of this Program cycle end output is set in this parameter. Setting 0.0 gives a maintained output at ST6 Pin 7-8.

**R56 Multi edge counter**

**1 = pulses x 1      2 = pulses x 2      4 = pulses x 4**

Entry of any other value will automatically select "1"

**R64 Direction of Manual Buttons**

	<b>Setting 0</b>	<b>Setting 1</b>
<b>Button 7 &amp; 8</b>	Backwards	Forwards
<b>Button 9 &amp; NR</b>	Forwards	Backwards

**R69 Speed of going to Datum in First phase, in switched speed control mode**

- Value xxxxx0 = creep speed to limit switch
- Value xxxxx1 = slow speed to limit switch
- Value xxxxx2 = Fast speed to limit switch

Approach to the maker pulse always in creep-speed.

### R88 System Register 4

This Register sets further basic functions of the controller.

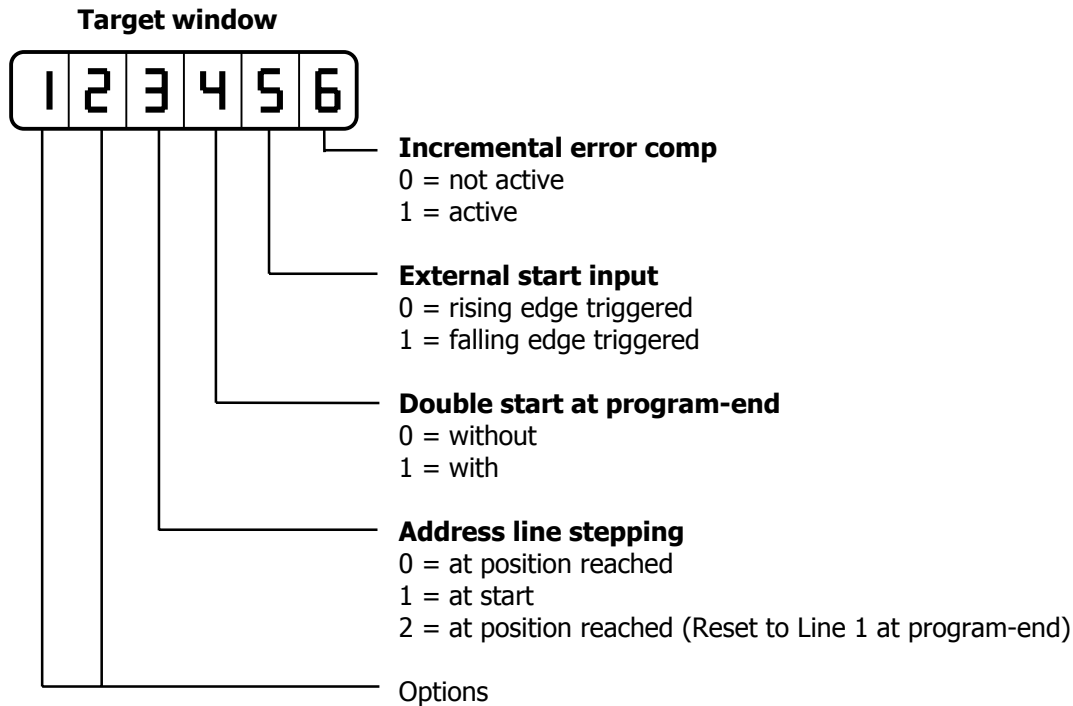

### R90 Service register

Only active when P98 is unlocked. Only for use during set-up of controller

### R94 "Free" Factor

Any factor value can be entered here between 0.00001 and 9.99999 and selected by R97 = xxxxx3. When the display is switched between metric/"inch", this factor will be used to change the display to secondary units.

### R96 Pulse factor (encoder)

A factor (0.00001 to 9.9999) can be entered in this Register. The incoming pulses will be multiplied by this factor, to manipulate the display to required dimensions. If no multiplication is required, this Register must be set to 1.00000.

### R97 Inch/mm conversion mode

The setting in this register activates the in inch mode, the free factor and the resolution in the inch mode can be selected. R97/6 =00000x

**0** = mm operation  
**1** = inch operation. Resolution 1/100  
**2** = inch operation. Resolution 1/1000  
**3** = factor operation. As set in R94

### R98 Security Code

Enter 250565 to unlock and change Parameters

### R99 Service register

For testing at factory set-up only.

## 8. Relay Configurations

These depend on setting of Register R8/5

**Value 0**      3 speed operation (Elgo standard default)  
 3 speeds selected by relays 2,3, & 4 Relay 5 sets direction reverse

**ST5 / Pin 3... 10, X = Pin's closed**

<b>RELAY outputs</b>	<b>3 - 4</b>	<b>5 - 6</b>	<b>7 - 8</b>	<b>9 - 10</b>
Creep forwards	<b>X</b>			
Slow forwards	<b>X</b>	<b>X</b>		
Fast forwards	<b>X</b>	<b>X</b>	<b>X</b>	
Creep reverse	<b>X</b>			<b>X</b>
Slow reverse	<b>X</b>	<b>X</b>		<b>X</b>
Fast reverse	<b>X</b>	<b>X</b>	<b>X</b>	<b>X</b>

R2 = Run, R3 = Slow, R4 = Fast combined with Run. R5 = reverse

**Value 1**      2 speed operation independent outputs forward and reverse  
 Independent outputs fast and slow

**ST5 / Pin 3... 10, X = Pin's closed**

<b>RELAY outputs</b>	<b>3 - 4</b>	<b>5 - 6</b>	<b>7 - 8</b>	<b>9 - 10</b>
Creep forwards	<b>X</b>	<b>X</b>		
Slow forwards				
Fast forwards	<b>X</b>		<b>X</b>	
Creep reverse		<b>X</b>		<b>X</b>
Slow reverse				
Fast reverse			<b>X</b>	<b>X</b>

R2 = Run forwards, R5 = Run reverse R3 = Creep, R4 = Fast, combined with forward / reverse (but independent)

**Value 2**      2 speed operation Speed set by Relays 2 & 3. Direction set by Relay 4

**ST5 / Pin 3... 10, X = Pin's closed**

<b>RELAY outputs</b>	<b>3 - 4</b>	<b>5 - 6</b>	<b>7 - 8</b>	<b>9 - 10</b>
Creep forwards	<b>X</b>	<b>X</b>		
Slow forwards				
Fast forwards	<b>X</b>		<b>X</b>	
Creep reverse	<b>X</b>	<b>X</b>		<b>X</b>
Slow reverse				
Fast reverse	<b>X</b>		<b>X</b>	<b>X</b>

R2 = Positioning (drive inhibit or brake)

R3 = Creep, R4 = Fast (both independent) R5 = reverse

**Value = 3** 2 speed operation Independent outputs for direction and speed

**ST5 / Pin 3... 10, X = Pin's closed**

<b>RELAY outputs</b>	<b>3 - 4</b>	<b>5 - 6</b>	<b>7 - 8</b>	<b>9 - 10</b>
Creep forwards	<b>X</b>			
Slow forwards				
Fast forwards		<b>X</b>		
Creep reverse			<b>X</b>	
Slow reverse				
Fast reverse				<b>X</b>

**Value = 4** 3 speed operation Forwards – 3 relays set speeds  
Reverse – always fast Output 5 = reverse

**ST5 / Pin 3... 10, X = Pin's closed**

<b>RELAY outputs</b>	<b>3 - 4</b>	<b>5 - 6</b>	<b>7 - 8</b>	<b>9 - 10</b>
Creep forwards	<b>X</b>			
Slow forwards	<b>X</b>	<b>X</b>		
Fast forwards	<b>X</b>	<b>X</b>	<b>X</b>	
Creep reverse	<b>X</b>	<b>X</b>	<b>X</b>	<b>X</b>
Slow reverse	<b>X</b>	<b>X</b>	<b>X</b>	<b>X</b>
Fast reverse	<b>X</b>	<b>X</b>	<b>X</b>	<b>X</b>

**Value = 5** 3 speed operation Binary coded Relays 2 & 3 for speed  
Relay 2 = Run forwards. Relay 5 = Run reverse

**ST5 / Pin 3... 10, X = Pin's closed**

<b>RELAY outputs</b>	<b>3 - 4</b>	<b>5 - 6</b>	<b>7 - 8</b>	<b>9 - 10</b>
Creep forwards	<b>X</b>	<b>X</b>		
Slow forwards	<b>X</b>		<b>X</b>	
Fast forwards	<b>X</b>	<b>X</b>	<b>X</b>	
Creep reverse		<b>X</b>		<b>X</b>
Slow reverse			<b>X</b>	<b>X</b>
Fast reverse		<b>X</b>	<b>X</b>	<b>X</b>

**Value 6** 3 speed operation Relay 2 = Run forwards. Relay 5 = Run reverse

**ST5 / Pin 3... 10, X = Pin's closed**

<b>RELAY outputs</b>	<b>3 - 4</b>	<b>5 - 6</b>	<b>7 - 8</b>	<b>9 - 10</b>
Creep forwards	<b>X</b>			
Slow forwards	<b>X</b>	<b>X</b>		
Fast forwards	<b>X</b>	<b>X</b>	<b>X</b>	
Creep reverse				<b>X</b>
Slow reverse		<b>X</b>		<b>X</b>
Fast reverse		<b>X</b>	<b>X</b>	<b>X</b>

## 9. Functions of Inputs (Terminals ST3 an ST4)

### St3/1 Terminal for pulling down signals to 0V (PNP-Standard Version)

(In optional NPN-Version this potential is for pulling up to + 24 V, Factory fitted only)

### St3/2 External start input

The start is edge triggered. Rising or falling edge can be selected in R88/5

### St3/3 External stop input

Input open → Stop active (no positioning possible)

**By pressing START at this moment a fault message "07" will be displayed!**

Input closed to St3/Pin1 → Stop is inactive (positioning possible)

The input logic for the Stop-input can be changed in the system parameter R 28/3

Value 0 = Stop active low (0 V, GND)

Value 1 = Stop active high (+ 24 V)

### St3/4 Set datum/reference

When Register R8/3 is set to 0 or 1, **datum** can be set by this input

**R8 = xx0xxx** referencing to Register 7

**R8 = xx1xxx** referencing to target value

**R8 = xx2xxx** Start of referencing in positive direction

**R8 = xx3xxx** Start of referencing in negative direction

### St3/5 Incremental negative

Activating this input causes axis to move incrementally in negative direction.

This input has priority over setting of R18/3 and R18/4.

In program operation, this input is only active if window "Abs/Incr." is inhibited.

### St3/6 Retract

Activating this input causes the axis to move in accordance with setting of R18/2

### St3/7 Quantity adding/subtracting

Each pulse on this input will increment or decrement the counter depending on setting of R18/6 = 1 - 6.

### St3/8 Incremental positive

Activating this input causes axis to move incrementally in positive direction.

This input has priority over setting of R18/3 and R18/4.

In program operation, this input is only active if Window A/I is inhibited.

**St4/1 Terminal for pulling down signals to 0V (PNP-Standard Version)**

(In optional NPN-Version this potential is for pulling up to + 24 V, Factory fitted only)

**St4/2 System Reset**

Activating this input will hold the controller in a reset condition, i.e. all outputs & displays are switched off and all other inputs are ignored (For test purpose only).

**St4/3 + 4**

**End switches** - External end switches can be connected at this pins.

<b>St4/Pin3 = End switch positive</b> <b>St4/Pin4 = End switch negative</b>
--

Input logic is NPN (input open = end switch active)

An activated end switch is monitored by following fault messages:

Fault monitoring :      Negative end switch active = error 02  
                                 Positive end switch active = error 03

<b>Notice: If these pins are not connected to end switches they need to be connected Normally closed (i.e. linked out).</b>
---

**St4/5 Fixed Position**

Activating this input starts the axis to move to fixed position set in R25.

## 10. Functions of Outputs Terminals ST5 & 6

### St5 pin 1-2 Position reached / in Position

The signal is a pulse of time set in R9. When R9 is set to zero, the output is latched till next start is given. The output is set when:

**Actual value = Demand value +/-Tolerance window R12**

Input of R9 = **0** → **static output**  
 Input of R9 = **0.1...99.9 sec** → **pulsing output** (according to adjusted pulse time)

### St5 pin 3-10 Run signals

In the parameter R8/5 the logical combination of the output relays 2-5 for the motion of the inverter ore the external relay logic can be selected. See pages 15/16 for the available combinations

### St6 pin 1-2 Drive enable

At Start this output is activated. When position is reached, output is reset after a time of R29.

### St6 pin 3-4 Quantity reached

The output is a pulse of time (0.0... 99.9 sec) set in R11 or a static signal (when R11 = 0). This will be active when the quantity is reached.

**For quantity subtracting → when batch counter = 0**  
**For quantity adding → when input value is reached.**

### St6/ pin 5-6 Program Running/ Program end

Parameter R30 select the function of this output.

#### **R30 = value 0**

- The output is set on first activation of start.
- The output is reset on completion of the last program line.

#### **R30 = value 0,1... 99,9 sec**

- The signal is a pulse according to the selected time.
- The output is set when last step of program is completed.

### ST 6 Pin 9-10 Program–overrun

The signal "program-overrun" can be selected as a static or a pulsing output. If the program counter is activated, (**R46 > 0**) and the program-overruns, (**R47 >= R46**) the output "program-overrun" will be set. If the register R48 is adjusted between 0,1... 99,9 sec., the output pulses according to the selected value.

Output as pulsing signal (**pulse time = R48**)

If the display-message „Count“, will be deactivated by pressing any key, the output "program-overrun" switches off immediately. Thereby it doesn't matter whether the pulse-time ran or not.

## 11. Connections

### ST 5 Relays 1-5

PIN	Function	
1 - 2	Pos. reached/in Pos	R1
3 - 4	Creep	R2
5 - 6	Slow	R3
7 - 8	Fast	R4
9 -10	Reverse	R5

The drive signal configurations are adjustable in different ways (see 8. Relay Configurations)

### ST 6 Relays 6-10

PIN	Function	
1 - 2	Drive enable	R6
3 - 4	Quantity reached	R7
5 - 6	Program running	R8
7 - 8	Option	R9
9 -10	Option	R10

### ST 2 Encoder

PIN	Function
1	0 V (GND)
2	+ 24 VDC
3	A Channel
4	B Channel
5	Earth & Screens

### ST 3 Input

PIN	Function
1	0 V (PNP) or 24 VDC (Option-NPN)
2	Start
3	Stop
4	Datum/reference
5	Incremental negative
6	Retract
7	Quantity
8	Incremental positive

### ST 4 Input

PIN	Function
1	0 V (PNP) or 24 VDC (Option-NPN)
2	System Reset
3	End switch negative
4	End switch positive
5	Start Home position
6	
7	
8	

### ST 9 DC Power supply

PIN	Function
1	0 V (GND)
2	24 VDC 250 mA
3	PE Earth & Screens

### ST 9 AC Power supply

PIN	Function
1	230/115 VAC 14 VA
2	230/115 VAC
3	PE Earth & Screens

### ST 7 Serial COM - RS232

PIN	Function
1	RX
2	TX
3	0 Volt

### ST 8 PID - Analogue output

PIN	Function
7	+/- 10 V analogue signal
8	0 Volt
9	PE Earth & Screens

## 11.1 Terminal assignment

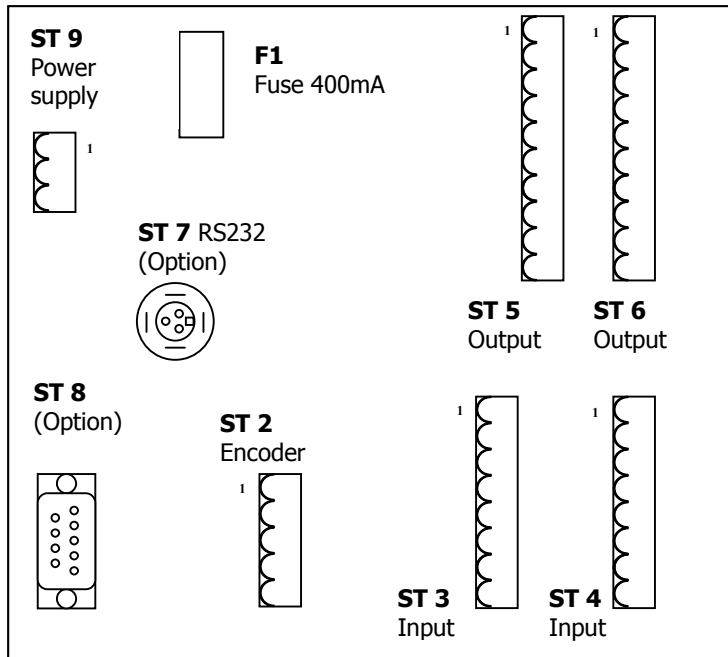

## 12. Technical specifications

<b>Power supply</b> (must be indicated)	24 VDC (index 024) 115 VAC 50/60 Hz (index 115) 230 VAC 50/60 Hz (index 230)
<b>Power consumption</b>	14 VA
<b>Consumption</b>	24 VDC max. 110 mA 115 /230 VAC max. 100 mA
<b>Encoder supply</b>	24 VDC max. load 130 mA
<b>Encoder circuit required</b>	PNP (NPN option)
<b>Input signals</b>	PNP (NPN option), minimum pulse time 0.3 sec
<b>Input current</b>	max. 10 mA
<b>Outputs</b>	Potential free shutter relays max. switch able voltage DC- 30 V max. switch able voltage AC- 250 V
<b>Memory</b>	E <sup>2</sup> -PROM minimum 10 years service life
<b>Connectors</b>	Screw terminals, strain relieved
<b>Display</b>	Red low power LED 7 segment 10 mm high
<b>Hardware</b>	SMD microprocessor with 128 K E-Prom
<b>System accuracy</b>	+/- 1 digit
<b>Counting frequency</b>	20 KHz, higher on request
<b>Housing</b>	Black, metal panel-housing 144 x 144 x 84 mm's plus 30 for connectors
<b>Cut-out</b>	138 x 138 mm
<b>Ambient temperature</b>	0... + 50 ° C

## 13. Installation/Wiring



**Attention!** To ensure a perfect function of the controller P8721 the following installation guide-lines must be strictly observed and followed. Otherwise the guarantee expires and **ELGO Electric GmbH** takes no liability and guarantee for malfunctions or damages caused e.g. by incorrect installed wires or other external sources of error or interference, which are exactly explained below. Please read the instructions carefully before putting the controller into operation.

**To guarantee a perfect operation of the controller, the following (external) measures have to be taken additionally:**

### **Place of installation:**

Don't install the controller near to sources of interference generating strong inductive or capacitive interferences or strong electrostatic fields.

Install the external power supply directly beside the controller to avoid long low voltage wires.

### **Power supply:**

Connect the external power supply to a phase of 230 VAC or 115 VAC, which is not used for engines. If not possible use a galvanic separation over an additional transformer.

### **Wire installation:**

Install all wires for low voltages and encoders always separately from power wires (230 VAC/400 VAC). Avoid to install these wires close to any contactor or contactor wires.

### **Shielding:**

All external signal wires have to be installed shielded:

1. Rotary encoder wires and Analog input wires
2. Wires for all other input signals
3. Wires for all output signals
4. Wires from the power supply to the controller

All shields have to be connected centrally low ohm to **PE** (earth potential), connect only one-sided at the P8721-Controller.

### **IMPORTANT!**

1. Don't connect the P8721-GND to **PE** (earth potential)
2. Don't connect the shielding on both sides to **PE** (earth potential)
3. If the protective ground potential is heavily "contaminated" by interference voltages, try to connect the shielding to the GND potential instead of **PE** (earth potential)

### **Fault clearance:**

If there occurs interferences in spite of applying all above mentioned measures proceed as follows:

1. Add RC elements over contactor reels of AC contactors (for example 0,1  $\mu$ F/100  $\Omega$ ).
2. Add recovery diodes over DC inductances
3. Add RC elements over each engine phase (in connector box of the engine)
4. Install a power filter before the external power supply

## 14. Only for Service

R99 Service Register

When R99 is selected, the following functions can be called up:-

Security Register R98 must be opened and service Register R90 set.

R90 = 000001 Button 0,1 and 4 active

R90 = 000002 All buttons active

Notice: Select R90 before R99!

Button 0 = Input test ST3

Button 1 = Input test ST4

Button 2 = Input/output test St3 to St5

Button 2 = Input/output test St4 to St6

Button 4 = Displays the software details  
Target window = SV number and version  
Quantity = SN number

Button 5 = Selects relay 1-5 output test on St5

Button 6 = Selects relay 6-10 output test on St6

Button 7 = Keyboard test

Button 8 = Clear memory

Button 9 = Load test program

Button R= Load default Register set

## 15. Type designation

**P 87 2 1 - 000 - 230 - 0 - R - XXXXXX**

**P = Position Controller**

**Series**  
**P8721** with Program memory

**Program Memory**

**Number of Axes**

**Construction**  
**000** = standard  
**001** = 1<sup>st</sup> special version  
etc.

**Supply voltage**  
**024** = 24 VDC  
**115** = 115 VAC  
**230** = 230 VAC

**Encoder input**  
**0** = A/B 24V/24V 20KHz PNP  
**1** = A/B/0 24V24V 20KHz PNP  
**2** = A/B/A'/B' (5 V-TTL), 100 KHz  
**3** = A/B/Z/A'/B'/Z' (5 V-TTL), 100 KHz  
**8** = A/B 24V /24 neg. logic NPN, 20 KHz

**Special Features**  
**P** = PID -Analogue output  
**R** = Relay output (7 shutters)  
**EN** = input NPN (including index pulse)  
**S** = Serial interface RS232

## 16. Liability exclusion / Guarantee

We have checked the contents of this instruction manual carefully, to the best of our knowledge and belief for conformity with the described hardware and software. Nevertheless errors, mistakes or deviations can not be excluded, therefore we do not guarantee complete conformity. Necessary corrections will be included in the subsequent editions. We appreciate your ideas and improvement suggestions very much. Reprint, duplication and translation, even in extracts, are only allowed with a written authorization by the company ELGO Electric GmbH. We constantly strive for improving our products, therefore we keep all rights reserved for any technical modifications without any notice.

ELGO Electric does not assume any liability for possible errors or mistakes.

The guarantee period is one calendar year from the date of delivery and includes the delivered unit with all components. ELGO Electric GmbH will at its option replace or repair without charge defects at the unit or the included parts, verifiable caused by faulty manufacturing and/or material in spite of proper handling and compliance to the instruction manual.

Damages verifiably not caused by ELGO-Electric GmbH and due to improper handling are excluded from any guarantee e.g. by applying faulty voltage, diffusion of liquid into the interior of the engine, using force, scratching the surface, chemical influences etc.!

*Subject to modifications © ELGO Electric GmbH 2004*

