

Eurotherm®

3500 Series

Dual Loop Controller/Programmer

Improve process efficiency, product quality and minimise waste

The latest range of advanced process controllers from Eurotherm™ provide precision control of temperature and a host of other process variables together with an abundance of advanced options making it the most adaptable product in its class.

The emphasis is on flexibility yet the 3500 controllers still maintain ease of use. A simple 'Quick Start' process is used to configure all the basic functions essential to controlling your process. This includes input sensor type, measurement range, control options and alarms making 'Out the Box' operation truly achievable. More advanced features are configured using a PC based graphical configuration tool enabling users to pick function blocks from a library then connect them together using soft wiring.

The large 5-digit display provides a clear and unambiguous indication of the process value. A four-line message centre provides custom or standard views of important information to the user while vertical and horizontal bargraphs provide at a glance visual indication of the process. Configuration Lock enables a user to protect their intellectual property by preventing unauthorized cloning of the configuration.

Dual loop

Two independent PID loops make the 3500 ideal for interactive processes such as those found in carburizing furnaces, environmental chambers and autoclaves. The loops may also be 'soft' wired together in creative ways to create cascade, ratio or other intelligent control strategies.

Setpoint programmer

Heat treatment and other processes often require the ability to change setpoints with time. The dual loop 3500 has two programmers which can be configured as synchronized or independent programs. 50 programs with up to two channels can be stored with a total of 500 segments.

Input/output flexibility

A range of plug-in I/O modules caters for individual application requirements minimizing stock and spares holding. A total of sixteen module types, including relay, logic, triac and analogue, are available to fit into either three slots on 3508 or six slots on 3504.



- 50 Programs
- Precision PV input
- Carbon potential
- Maths/logic/timers
- Custom user interface
- Recipes
- Digital communications
 - Ethernet : DUAL RJ45 port
 - Modbus TCP Server and Client
 - Modbus RTU Server and Client
 - DeviceNet® network
 - Configuration Lock
 - Multi-language support (English, French, German, Spanish and Italian)

Carbon potential

The 3500 calculates carbon potential from measuring both the oxygen concentration and temperature of a furnace using a zirconia probe. This enables a dual loop 3500 to be used to control both carbon potential and temperature in an atmosphere controlled furnace.

Customized solutions

The 3500 is more than just a process controller. It also provides a selection of application blocks including maths, logic and timing functions offering the ability to develop custom solutions and create cost effective machine controllers. The custom User Page feature allows an operator to view current information in a style most suitable to the process and terminology of the industry.

Communications

The 3500 is designed to integrate seamlessly with programmable logic controllers and other supervisory systems. A wide range of serial communication options are catered for including EIA232 and EIA485 using the Modbus RTU protocol along with DeviceNet. Ethernet connectivity is achieved using the Modbus TCP protocol.

Recipes

Using a PC tool recipes can be created that can be used to change the operating parameters of the 3500 simply by selecting a new recipe via the HMI. This is very useful where multiple products are processed using the same controller but require different parameters to be set.

Infrared configuration adaptor

Communications to the 3500 can be achieved by using an infrared adaptor. Clipping onto the front fascia it provides Eurotherm iTools communications allowing configuration and commissioning to be performed without the need to access the rear terminals of the controller.



Infrared clip connected to the 3504

Eurotherm iTools Graphical Wiring Editor

The GWE is an extremely easy way to create applications. It allows users to select the function blocks they wish to use in their application then connect them together using 'Soft Wiring'. The GWE gives the user a pictorial view of exactly what he has configured and can also be used to monitor runtime conditions.

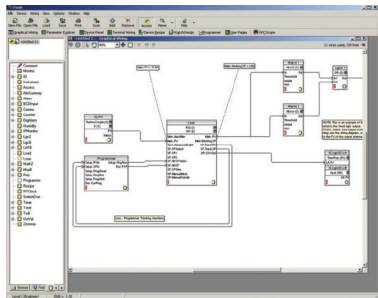

IO Expander

Extra IO can be provided by the IO Expander. Options are available for 10in 10out and 20in 20out.

Specification

General

Environmental performance

Temperature limits:	Operation: 0 to 50°C Storage: -10 to 70°C
Humidity limits:	Operation: 5% to 85% RH non condensing Storage: 5% to 95% RH non condensing
Panel sealing:	IP65, NEMA12
Vibration:	2g peak, 10 to 150Hz
Altitude:	<2000 metres
Atmospheres:	Not suitable for use in explosive or corrosive atmosphere*

Electromagnetic compatibility (EMC)

Emissions and immunity:	BS EN61326
Suitable for domestic, commercial and light industrial as well as heavy industrial. (Domestic/light (Class B) emissions. Industrial (Class A) environmental immunity emissions.	
With Ethernet module fitted product only suitable for Class A emissions	

Electrical safety

BS EN61010:	Installation cat. II; Pollution degree 2
INSTALLATION CATEGORY II The rated impulse voltage for equipment on nominal 230V ac mains is 2500V.	
POLLUTION DEGREE 2 Normally, only non-conductive pollution occurs. Occasionally, however, a temporary conductivity caused by condensation shall be expected.	

Physical

Dimensions:	3508: 48W x 96H x 159Dmm 3504: 96W x 96H x 159Dmm
Weight:	3508: 400g 3504: 600g
Panel:	3508: 1/8 DIN mounting 45W x 92Hmm cut-out 3504: 1/4 DIN mounting 92W x 92Hmm cut-out
Panel depth:	Both: 148mm

Operator interface

Type:	STN LCD with backlight
Main PV display:	3508: 4 1/2 digits, green 3504: 5 digits, green
Panel:	3508: 1/8 DIN mounting 45W x 92Hmm cut-out 3504: 1/4 DIN mounting 92W x 92Hmm cut-out
Panel depth:	Both: 148mm
Message display:	3508: 8 character header and 3 lines of 10 characters 3504: 16 character header and 3 lines of 20 characters
Status beacons:	Units, outputs, alarms, program status, program events, active setpoint, manual, remote SP
Access levels:	3 operator plus config. Password protected

Power requirements

Supply voltage:	100 to 230V ac, ±15%, 48 to 62Hz, max 20W (3508 15W) 24V ac, -15%, 24V ac, -15%, +20% ±5% ripple voltage max 20W (3508 15W)
Interrupt protection:	Standard: Holdup >10ms at 85V RMS supply voltage Low voltage: Holdup >10ms at 20.4V RMS supply voltage
Inrush current:	High Voltage: (VH) : 30A duration <100µS Low Voltage: (VL) : 15A duration <100µS

User page

Number:	8
Parameters:	64 total
Functions:	Text, conditional text, values, bargraph
Access level:	User selectable (level 1, 2 or 3)

Approvals

CE, cUL listed (file E57766), EAC. Suitable for use in Nadcap and AMS2750 applications under System Accuracy Test calibration conditions

Communications

No of ports	2 modules can be fitted
Slot allocation:	Modbus RTU (H or J comms port) or I/O expander (J comms port only)

Serial communications option

Protocols:	Modbus Client/Server Slot H only EI-Bisync (818 style mnemonics) Modbus Client/Server broadcast (1 parameter) Slot J only
Isolation:	264V ac, double insulated
Transmission standard:	EIA232, EIA485, CAN (DeviceNet),

Ethernet communications option: 10/100Base Tx (Dual port)

Protocol:	Modbus TCP, Modbus Client/Server (H comms only)
Isolation:	264V ac, double insulated
Transmission standard:	802.3
Features:	DHCP client, 4 simultaneous clients

Main process variable input

Calibration accuracy:	<±0.1% of reading ±1LSD (Note 1)
Sample rate:	9Hz (110ms)
Isolation:	264V ac double insulation from the PSU and communication
Input filter:	Off to 59.9s. Default 1.6s
Zero offset:	User adjustable over full ran
User calibration:	2-point gain & offset

Thermocouple

Range:	Uses 40mV and 80mV ranges dependent on type
Types:	K, J, N, R, S, B, L, T, C, PL2, custom download x 2
Resolution:	16 bits
Linearisation accuracy:	<0.2% of reading
Cold junction compensation:	>40:1 rejection of ambient change External reference of 0°C, 45°C and 50°C
Cold junction accuracy:	<±1°C at 25°C ambient

Resistance thermometer

Range:	0-400Ω (-200°C to +850°C)
Resistance thermometer types:	3-wire Pt100 DIN 43760
Resolution (°C):	<0.050°C with 1.6sec filter
Resolution:	16 bits
Linearity error:	<±0.03% (best fit straight line)
Calibration error:	<±0.310°C/°C, ±0.023% of measurement at 25°C
Drift with temperature:	<±0.010°C/°C, ±25ppm/C of measurement from 25°C
Common mode rejection:	<0.000085°C/V (maximum of 264V rms)
Series mode rejection:	<0.240°C/V (maximum of 280mV pk-pk)
Lead resistance:	0Ω to 22Ω, matched lead resistance
Input impedance:	100MΩ
Bulb current:	200µA

40mV Range

Range:	-40mV to +40mV
Resolution (µV):	<1.0µV with 1.6sec filter
Resolution:	16 bits
Linearity error:	<0.003% (best fit straight line)
Calibration error:	<±4.6µV, ±0.053% of measurement at 25°C
Drift with temperature:	<±0.2µV/C, ±28ppm/C of measurement from 25°C
Common mode rejection:	>175dB (maximum of 264V rms)
Series mode rejection:	>101dB (maximum of 280mV pk-pk)
Input leakage current:	±14nA
Input impedance:	100MΩ

80mV Range

Range:	-80mV to +80mV
Resolution (µV):	<3.3µV with 1.6sec filter
Resolution:	16 bits
Linearity error:	<0.003% (best fit straight line)
Calibration error:	<±7.5µV, ±0.052% of measurement at 25°C
Drift with temperature:	<±0.2 V/°C, ±28ppm/C of measurement from 25°C
Common mode rejection:	>175dB (maximum of 264V rms)
Series mode rejection:	>101dB (maximum of 280mV pk-pk)
Input leakage current:	±14nA
Input impedance:	100MΩ

2V Range

Range:	-1.4V to +2.0V
Resolution (mV):	<90µV with 1.6sec filter
Resolution:	16 bits
Linearity error:	<0.015% (best fit straight line)
Calibration error:	<±420µV, ±0.044% of measurement at 25°C
Drift with temperature:	<±125 V/C, ±28ppm/C of measurement from 25°C
Common mode rejection:	>155dB (maximum of 264Vrms)
Series mode rejection:	>101dB (maximum of 4.5V pk-pk)
Input leakage current:	±14nA
Input impedance:	100MΩ

10V Range

Range:	-3.0V to +10.0V
Resolution (mV):	<550µV with 1.6sec filter
Resolution:	16 bits
Linearity error:	<0.007% of reading for zero source resistance. Add 0.003% for each 10Ω of source plus lead resistance
Calibration error:	<±1.5mV, ±0.063% of measurement at 25°C
Drift with temperature:	<±66µV/C, ±60ppm/C of measurement from 25°C
Common mode rejection:	>145dB (maximum of 264V rms allowed)
Series mode rejection:	>92dB (maximum of 5V pk-pk allowed)
Input impedance	62.5kΩ to 667kΩ depending on input voltage

Notes

1. Calibration accuracy quoted over full ambient operating range and for all input linearisation types

Digital IO (LA and LB)

Isolation:	Not isolated from each other. 264V ac double insulation from the PSU and communication
------------	--

Input

Rating:	Voltage level: Closed 0 to 7.3V dc Open 10.8 to 24V dc Contact closure: Open >1200Ω Closed <480Ω
---------	---

Functions	Includes program control, alarm acknowledge, SP2 select, manual, keylock, RSP select, standby
-----------	---

Output

Rating:	18V dc >9mA <15mA
Functions	Includes control outputs, alarms, events, status

AA Relay

Rating:	Min 1mA @ 1V dc, Max 2A @ 264V ac resistive 1,000,000 operations with external snubber
Isolation:	264Vac double insulation
Functions:	Includes control outputs, alarms, events, status

Input / Output modules

IO Modules	3508: 3 modules can be fitted 3504: 6 modules can be fitted
------------	--

IO Expander:	20 Digital inputs, 20 relay outputs
--------------	-------------------------------------

Analogue input module

Calibration accuracy:	±0.2% of reading ±1LSD
Sample rate:	9Hz (110ms)
Isolation:	264V ac double insulation
Input filter:	Off to 59.9s. Default 1.6s
Zero offset:	User adjustable over full range
User calibration:	2-point gain & offset
Functions:	Includes process input, remote setpoint, power limit

Thermocouple

Range:	-100mV to +100mV
Types:	K, J, N, R, S, B, L, T, C, PL2, custom
Resolution (µV):	<3.3µV @ 1.6s filter time
Effective resolution:	15.9 bits
Linearisation accuracy:	<0.2% of reading
Cold junction compensation:	>25:1 rejection of ambient change External reference of 0°C, 45°C and 50°C
Cold junction accuracy:	<±1°C at 25°C ambient

Resistance thermometer

Range:	0-400Ω (-200°C to +850°C)
Resistance thermometer types:	3-wire Pt100 DIN 43760
Resolution (°C):	<±0.08°C with 1.6sec filter
Effective resolution:	13.7 bits
Linearity error:	<0.033% (best fit straight line)
Calibration error:	<±(0.4°C +0.15% of reading in °C)
Drift with temperature:	<±(0.015°C +0.005% of reading in °C) per °C
Common mode rejection:	<0.000085°C/V (maximum of 264V rms)
Series mode rejection:	<0.240°C/V (maximum of 280mV pk-pk)
Lead resistance:	0Ω to 22Ω, matched lead resistance
Bulb current:	300μA

100mV Range

Range:	-100mV to +100mV
Resolution (μV):	<3.3μV with 1.6s filter time
Effective resolution:	15.9 bits
Linearity error:	<0.033% (best fit straight line)
Calibration error:	<±10μV, ± 0.2% of measurement at 25°C
Drift with temperature:	<±0.2 V + 0.004% of reading per °C
Common mode rejection:	>146dB (maximum of 264V rms)
Series mode rejection:	>90dB (maximum of 280mV pk-pk)
Input leakage current:	<1nA
Input impedance:	>100M

2V Range

Range:	-0.2V to +2.0V
Resolution (μV):	30μV with 1.6s filter time
Effective resolution:	16.2 bits
Linearity error:	<0.033% (best fit straight line)
Calibration error:	<±2mV + 0.2% of reading
Drift with temperature:	<±0.1mV + 0.004% of reading per °C
Common mode rejection:	>155dB (maximum of 264Vrms)
Series mode rejection:	>101dB (maximum of 4.5V pk-pk)
Input leakage current:	<10nA
Input impedance:	>100M

10V Range

Range:	-3.0V to +10.0V
Resolution (μV):	<200μV with 1.6sec filter
Effective resolution:	15.4 bits
Linearity error:	<0.033% (best fit straight line)
Calibration error:	<±0.1mV + 0.02% of reading per °C
Drift with temperature:	<± 0.1mV + 0.02% of reading per °C
Common mode rejection:	>145dB (maximum of 264V rms)
Series mode rejection:	>92dB (maximum of 5V pk-pk)
Input impedance:	>69kΩ

Potentiometer input

Type:	Single channel
Resistance:	100Ω to 15kΩ
Excitation:	0.5V dc supplied by module
Isolation:	264V ac double insulation
Functions:	Includes valve position and remote setpoint

Analogue control output

Type:	Single channel
Rating:	0-20mA <600Ω 0-10V dc >500Ω
Accuracy:	<±2.5%
Resolution:	10 bits
Isolation:	264V ac double insulation

Analogue retransmission output

Type:	Single channel
Rating:	0-20mA <600Ω 0-10V dc >500Ω
Accuracy:	<±0.5%
Resolution:	11 bits
Isolation:	264V ac double insulation

Dual 4-20mA OP/24V dc TxPSU

Type:	Dual channel
Rating Output:	4-20mA dc, <1KΩ
TxPSU:	24V dc, 22mA
Isolation:	264V ac double insulation between channels
Functions:	Either channel can be control output or TxPSU
Accuracy:	<±1%
Resolution:	11 bits

Logic input modules

Module types:	Triple contact closure, triple logic level
Isolation:	No channel isolation. 264V ac double insulation from other modules and system
Rating:	Voltage level: Open -3 to 5V dc @ <-0.4mA Closed 10.8 to 30V dc @ 2.5mA
Contact closure:	Open >28kΩ Closed <100Ω
Functions:	Includes program control, alarm acknowledge, SP2 select, manual, keylock, RSP select, standby

Logic output modules

Module types:	Single channel, triple channel
Isolation:	No channel isolation. 264V ac double insulation from other modules and system
Rating Single:	12V dc >20mA <29mA
Triple:	12V dc >9mA <12mA
Functions:	Includes control outputs, alarms, events, status

Relay modules

Module types:	Single channel Form A, Single channel Form C, dual channel Form A
Isolation:	264V ac double insulation
Rating:	Min 100mA @ 12V dc, Max 2A @ 264V ac resistive Min 400,000 (max load) operations with external snubber
Functions:	Includes control outputs, alarms, events, status

Triac modules

Module types:	Single channel, dual channel
Isolation:	264V ac double insulation
Rating:	<0.75A @ 264V ac resistive
Functions:	Includes control outputs, alarms, events, status

Transmitter PSU module

Type:	Single channel
Isolation:	264V ac double insulation
Rating:	24V dc @ 20mA

Transducer PSU module

Type:	Single channel
Isolation:	264V ac double insulation
Bridge voltage:	Software selectable 5V dc or 10V dc
Bridge resistance:	300Ω to 15kΩ
Internal shunt resistor:	30.1Ω @0.25%, used for calibration of 350Ω bridge at 80%

I/O Expander

Type:	20 I/O: 4 Form C relays, 6 Form A relays, 10 logic inputs 40 I/O: 4 Form C relays, 16 Form A relays, 20 logic inputs
Isolation:	264V ac double insulation between channels
Ratings:	Relay: Min 100mA @ 12V dc, Max 2A @ 264V ac resistive Logic Input: Open -3 to 5V dc @ <-0.4mA Closed 10.8 to 30V dc @ 2.5mA
Communications:	Using EX comms module in comms slot J

Software features

Control	
Number of loops:	2
Loop update:	110ms
Control types:	PID, OnOff, VP, Dual VP
Cooling types:	Linear, fan, oil, water
Modes:	Auto, manual, forced manual, control inhibit
Overshoot inhibition:	High and low cutbacks
Number of PID sets:	3, selectable on PV, SP, OP, On Demand, program segment and remote input
Control options:	Supply voltage compensation, feedforward, output tracking, OP power limiting, SBR safe output
Setpoint options:	Remote SP with trim, SP rate limit, 2nd Setpoint, tracking modes

Setpoint programmer

Program function:	50 programs, max 500 segments
Program names:	User defined up to 16 characters
No of profile channels:	2 (1 if single loop)
Operation:	Full or partially synchronised
Events:	8 per channel (8 when fully synchronised) 1 timed event, 1 PV event
Segment types:	Rate, dwell, time, call, goback and wait
Digital inputs:	Run, Hold, Reset, RunHold, RunReset, Adv Seg, Skip Seg
Servo action:	Process value, setpoint
Power failure modes:	Continue, ramp, reset
Other functions:	Guaranteed soak, holdback, segment user values, wait inputs, PV hot start

Process/Digital Alarms

Number:	16
Type:	Abs Hi, Abs Lo, Dev Hi, Dev Lo, Dev Band, Dig Hi, Dig Lo, Pos Edge, Neg Edge, Edge and Abs Hi/Lo
Latching:	None, Auto, manual, event
Other features:	Delay, inhibit, blocking, display message, 3 priority levels

Zirconia

Number:	1
Functions:	Carbon potential, dewpoint, %O2 LogO2, probe mV
Supported probes:	Barber Colman, Drayton, MMICarbon, AACC, Accucarb, SSI, MacDhui, BoschO2, BoschCarbon
Gas reference:	Internal or remote analogue input
Probe diagnostics:	Clean recovery time, impedance measurement
Probe burn-off:	Automatic or manual
Other features:	Sooting alarm with tolerance setting, PV

Humidity

Number:	1
Functions:	Relative humidity, dewpoint
Measurement:	Psychrometric (wet & dry) inputs
Atmosphere compensation:	Internal or remote analogue input
Other features:	Psychrometric constant adjust

Recipes

Number:	8
Parameters:	40 per recipe
Length of name:	8 Characters
Selection:	HMI, comms, strategy

Transducer calibration

Number:	2
Type:	Shunt, load cell, comparison
Other features:	Autotare

Communication tables

Number:	250
Function:	Modbus remapping (indirection)
Data formats:	Integer, IEEE (full resolution)

Application blocks

Soft wiring:	Orderable options of 30, 60, 120, 250 or 360
User values:	16 as standard, 40 with 360 wires, real numbers with decimal point
2 IP maths:	24 as standard, 32 with 360 wires. add, subtract, multiply, divide, absolute difference, max, min, hot swap, sample and hold, power, square root, Log, Ln, exponential, switch
2 IP logic:	24 as standard, 40 with 360 wires AND, OR, XOR, latch, equal, not equal, greater than, less than, greater than or equal to, less
8 IP logic:	2 as standard, 4 with 360 wires AND, OR, XOR
8 IP multiplexor:	4 as standard, 8 with 360 wires 8 sets of 8 values selected by input parameter
8 IP multiple IP:	2 as standard, 4 with 360 wires average, min, max sum
BCD Input:	2 blocks, 2 Decades
Input monitor:	2 blocks, max, min, time above threshold
32 point linearisation:	2 as standard, 8 with 360 wires, 32-point linearization fit
Polynomial fit:	2 blocks, characterisation by Poly Fit table
Switchover:	1 block, smooth transition between 2 values
Timer blocks:	4 blocks, OnPulse, OnDelay, OneShot, MinOn Time
Counter blocks:	2 blocks, Up or down, directional flag
Totaliser blocks:	2 blocks, alarm at threshold value

Installation

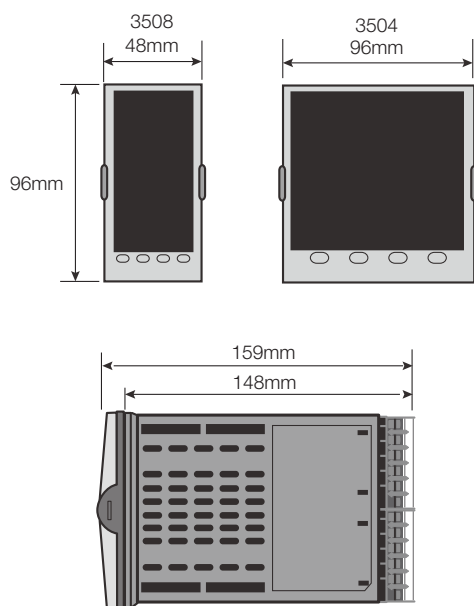

3508 Panel cut-out 92mm (-0.0 +0.8) x 45mm (-0.0 +0.6)
3504 Panel cut-out 92mm (-0.0 +0.8) x 92mm (-0.0 +0.8)

Isolation

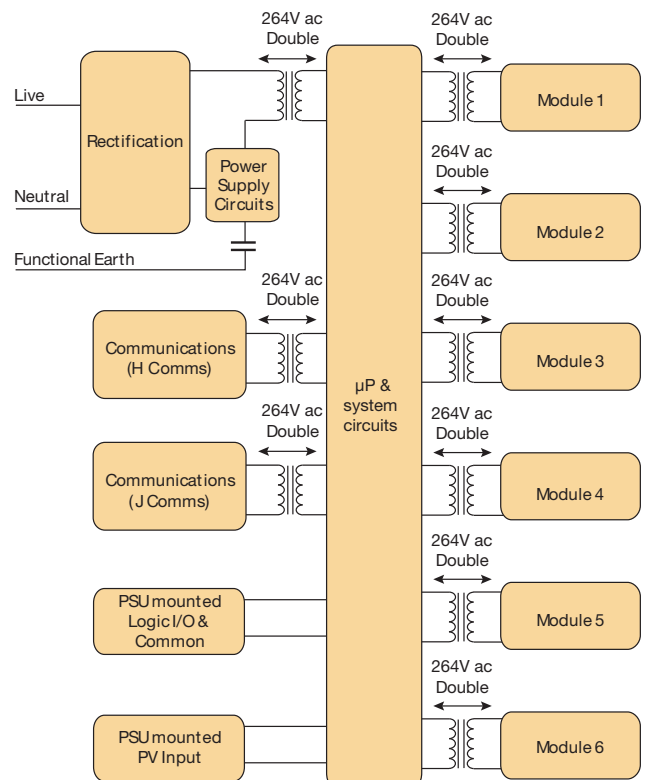

Order Code Hardware/options coding

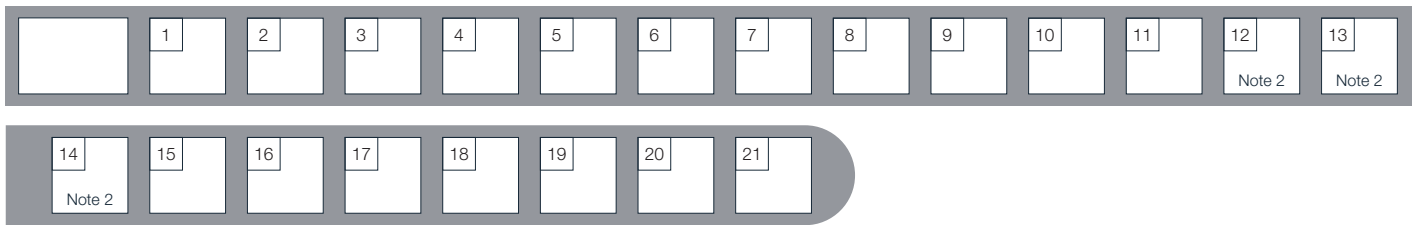

Basic Product	
3508	48 x 96mm unit
3504	96 x 96mm unit

1 Function	
CCE	Standard

2 Supply Voltage	
VH	85-264V ac
VL	VL 24V ac/dc

3 Loops	
1	One loop
2	Two loops

4 Application	
XX	Standard
ZC	Zirconia
VP	VP Dual Valve Positioning (Note 3)

5 Program	
XX	No programs
1	1 Progs - 20 Segments
10	10 Progs - 500 Segments
25	25 Progs - 500 Segments
50	50 Progs - 500 Segments

6 Recipes	
X	No recipes
8	8 Recipes

7 Toolkit Wires	
XXX	Standard 30 Wires
60	60 Wires
120	120 Wires
250	250 Wires
360	360 Wires

8 Fascia	
G	Eurotherm green
S	Silver

9-14 IO Slots 1-6 (Note 2)	
XX	No module fitted
R4	Change over relay
R2	2 pin relay
RR	Dual relay
T2	Triac
TT	Dual triac
D4	DC control
AM	Analogue input (not slot 2 or 5)
D6	DC retransmission
TL	Triple logic input
TK	Triple contact input
TP	Triple logic output
VU	Potentiometer input
MS	24V dc transmitter PSU
G3	Transducer PSU 5 or 10V dc
DO	Dual 4-20mA OP/24V dc PSU (Slots 1, 2 or 4 only)
LO	Isolated single logic OP

15 H Comms Slot	
XX	Not fitted
A2	EIA232 Modbus
Y2	2-wire EIA485 Modbus
F2	4-wire EIA485 Modbus
AE	EIA232 EI-Bisynch ^{Note 1}
YE	2-wire EIA485 EI-Bisynch ^{Note 1}
M1	RS232 Modbus Client
M2	2-wire EIA485 Modbus Client
M3	4-wire EIA485 Modbus Client
FE	4-wire EIA485 EI-Bisynch ^{Note 1}
E2	Ethernet 10/100 BASE-TX dual port
E3	Ethernet 10/100 BASE-TX dual port with Modbus Client
DN	DeviceNet

16 J Comms Slot	
XX	Not fitted
A2	EIA232 Modbus
Y2	2-wire EIA485 Modbus
F2	4-wire EIA485 Modbus
AE	EIA232 EI-Bisynch ^{Note 1}
YE	2-wire EIA485 EI-Bisynch ^{Note 1}
FE	4-wire EIA485 EI-Bisynch ^{Note 1}
M1	RS232 Modbus Client
M2	2-wire EIA485 Modbus Client
M3	4-wire EIA485 Modbus Client
EX	IO Expander module

17 Configuration Lock Function	
XX	None
LK	Configuration Lock

18 Product Language	
ENG	English
FRA	French
GER	German
SPA	Spanish
ITA	Italian

19 Manual Language	
ENG	English
FRA	French
GER	German
SPA	Spanish
ITA	Italian

20 Warranty	
XXXXX	Standard
WL005	Extended Warranty

21 Calibration Certificate	
XXXXX	None
CERT1	Certificate of Conformity
CERT2	Factory Cal certificate



Notes

- Consult Factory for availability
- I/O slots 4, 5 and 6 are only available on the 3504
- Provides Valve Position option in Heat/Cool applications. Single channel VP included as standard
- If standard config is selected an instrument without configuration will be supplied.
- If C or F units are selected they must be the same for both loops. If C or F are not selected for Loop 1 they cannot be selected for Loop 2.

3500 Accessories

SUB35/ACCESS/249R.1	2.49R Precision resistor
iTools/None/3000IR	Configuration IR clip
iTools/None/3000CK	Configuration clip
2000IO/VL/10LR/XXXX	10IN, 10OUT Expander
2000IO/VL/20LR/20LR	20IN, 20OUT Expander

Table 1	
A	4-20mA Linear
Y	0-20mA Linear
W	0-5V dc Linear
G	1-5V dc Linear
V	0-10V dc Linear

Configuration coding

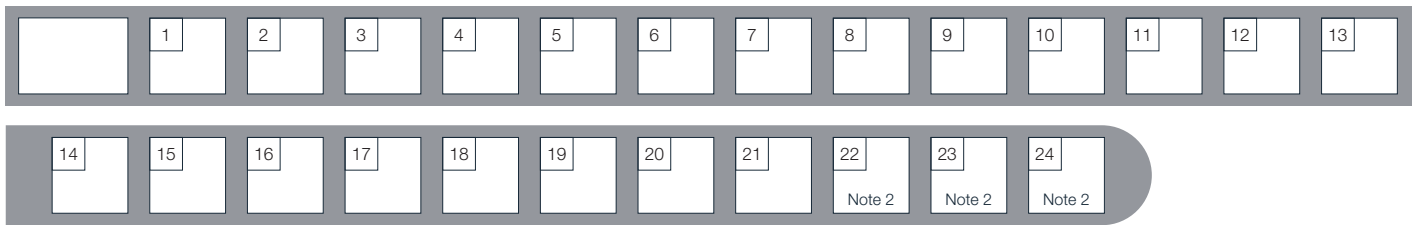

1 Configuration	
STD	Standard config. (Note 4)
CFG	Factory configured

2 Loop 1 Units	
C	Centigrade
F	Fahrenheit
%	Percent
H	%RH
P	PSI
B	Bar
M	mBar
X	None

3 Loop 1 Function	
PX	Single Channel PID
FX	Single Ch Valve with feedback
VX	Single Ch Valve w/out feedback
NX	Single Ch On/Off
PP	Dual Channel PID
PN	Dual Ch PID/OnOff
FF	Dual Ch Valve with feedback
VV	Dual Ch Valve w/out feedback
PF	Dual Ch PID/Valve with feedback
PV	Dual Ch PID/Valve w/o feedback

4 Loop 1 PV (from Main PV)	
X	Unconfigured
J	J Thermocouple
K	K Thermocouple
T	T Thermocouple
L	L Thermocouple
N	N Thermocouple
R	R Thermocouple
S	S Thermocouple
B	B Thermocouple
P	Platinell II
C	C Thermocouple
Z	Pt 100
A	4-20mA Linear
Y	0-20mA Linear
W	0-5V dc Linear
G	1-5V dc Linear
V	0-10V dc Linear
D	D Thermocouple
E	E Thermocouple
1	Ni/Ni 18% MO
2	Pt20%Rh/Pt40%Rh
3	W/W26%Re (Englehard)
4	W/W26%Re (Hoskins)
5	W5%Re/W26%Re (Englehard)
6	W5%Re/W26%Re (Bucose)
7	Pt10%Rh/Pt40%Rh
Q	Custom Curve

5 Loop 1 Range Low	
XXXX	Enter value with decimal point

6 Loop 1 Range High	
XXXX	Enter value with decimal point

7 Loop 2 Units	
C	Centigrade (Note 5)
F	Fahrenheit (Note 5)
%	Percent
H	%RH
P	PSI
B	Bar
M	mBar
X	None

8 Loop 2 Function	
XX	Single Loop Only
PX	Single Channel PID
FX	Single Ch Valve with feedback
VX	Single Ch Valve w/out feedback
NX	Single Ch On/Off
PP	Dual Channel PID
PN	Dual Ch PID/OnOff
FF	Dual Ch Valve with feedback
VV	Dual Ch Valve w/out feedback
PF	Dual Ch PID/Valve with feedback
PV	Dual Ch PID/Valve w/o feedback

9 Loop 2 PV	
X	Unconfigured
J	J Thermocouple
K	K Thermocouple
T	T Thermocouple
L	L Thermocouple
N	N Thermocouple
R	R Thermocouple
S	S Thermocouple
B	B Thermocouple
P	Platinell II
C	C Thermocouple
Z	Pt 100
A	4-20mA Linear
Y	0-20mA Linear
W	0-5V dc Linear
G	1-5V dc Linear
V	0-10V dc Linear
D	D Thermocouple
E	E Thermocouple
1	Ni/Ni 18% MO
2	Pt20%Rh/Pt40%Rh
3	W/W26%Re (Englehard)
4	W/W26%Re (Hoskins)
5	W5%Re/W26%Re (Englehard)
6	W5%Re/W26%Re (Bucose)
7	Pt10%Rh/Pt40%Rh
Q	Custom Curve

10 Loop 2 Range Low	
XXXX	Enter value with decimal point

11 Loop 2 Range High	
XXXX	Enter value with decimal point

12-15 Alarms 1-4	
XXX	Unconfigured
1_	Loop 1
2_	Loop 2
_FH	Full scale high
_FL	Full scale low
_DH	Deviation high
_DL	Deviation low
_DB	Deviation band

16-17 Logic LA and Logic LB	
XX	Unconfigured
1_	Loop 1
2_	Loop 2
_B	Sensor Break
_BM	Manual Select
_H	Control Ch1 O/P
_C	Control Ch2 O/P
_R	Remote SP
_S	Setpoint 2 Enable
A	Alarm
_A	Acknowledge all Alarms
_1	Alarm 1 O/P
_2	Alarm 2 O/P
P	Programmer
_R	Run
_H	Hold
_A	Reset
_1	Prog Ch1 Event 1
_2	Prog Ch1 Event 2

18 Relay AA	
XX	Unconfigured
1_	Loop 1
2_	Loop 2
_H	Control Ch1 O/P
_C	Control Ch2 O/P
_B	Sensor Break
SB	Sensor Break (any loop)
A	Alarm
_A	Any Alarm Active
_N	_N New Alarm Active
_1	_1 Alarm 1 O/P
_2	_2 Alarm 2 O/P
P	Programmer
_1	Prog Ch1 Event 1
_2	Prog Ch1 Event 2

19-24 Logic LA and Logic LB	
XXX	Unconfigured
1_	Loop 1
2_	Loop2

Changeover Relay (R4)	
_HX	Control Ch1 O/P
_CX	Control Ch2 O/P
_BX	Sensor Break

2-Pin Relay (R2)	
_HX	Control Ch1 O/P
_CX	Control Ch2 O/P
_BX	Sensor Break

Single Logic (LO)	
_HX	Control Ch1 O/P
_CX	Control Ch2 O/P

Single Triac (T2)	
_HX	Control Ch1 O/P
_CX	Control Ch2 O/P

Dual Relay (RR)	
_HC	Ch1 O/P and Ch2
_VT	VP Ch1
_VR	VP Ch2
P12	Prog Event 1 and 2
P34	Prog Event 3 and 4
P56	Prog Event 5 and 6
P78	Prog Event 7 and 8
A12	Alarm 1 and 2 O/P
A34	Alarm 3 and 4 O/P
HHX	Ch1 O/P for loops 1 and 2
CCX	Ch2 O/P for loops 1 and 2
SBR	Sensor Break both loops

19-24 ... continued	
Dual Triac (TT)	
_HC	Ch1 O/P and Ch2
_VH	VP Ch1
_VC	VP Ch2
P12	Prog Ch1 Event 1 and 2
P34	Prog Ch1 Event 3 and 4
P56	Prog Ch1 Event 5 and 6
P78	Prog Ch1 Event 7 and 8
A12	Alarm 1 and 2 O/P
A34	Alarm 3 and 4 O/P
HHX	Ch1 O/P for loops 1 and 2
CCX	Ch2 O/P for loops 1 and 2

DC Control (D4)	
For range select third digit from Table 1	
H	Ch1 O/P
C	Ch2 O/P

DC Retransmission (D6)	
For range select third digit from Table 1	
_T	PV Retransmission
_S	SP Retransmission

Analogue Input (AM)	
For range select third digit from Table 1	
2PV	Loop 2 PV
R	Remote SP

Analogue Input (AM)	
For range select third digit from Table 1	
2PV	Loop 2 PV
R	Remote SP

Potentiometer Input (VU)	
_RS	Remote SP
_VF	Valve Feedback Ch1
_VG	Valve Feedback Ch2

Dual 4-20mA O/P/TxPSU	
_HC	Ch1 O/P and Ch2 O/P
_HT	Ch1 O/P loops1, TxPSU
HHX	Ch O/P for loops 1 and 2
TTX	Both channels TxPSU

Triple Logic IP (TL) or (TK)	
---	Select function below for each ch
X	Unconfigured
M	Loop 1 Manual
N	Loop 2 Manual
Q	Loop 1 Remote SP
V	Loop 2 Remote SP
S	Loop 1 Setpoint 2 enable
T	Loop 2 Setpoint 2 enable
E	Acknowledge all Alarms
P	Program Run
R	Program Reset
H	Program Hold

Triple Logic OP (TP)	
---	Select function below for each ch
X	Unconfigured
F	Loop 1 Control Ch1 O/P
G	Loop 1 Control Ch2 O/P
K	Loop 2 Control Ch1 O/P
L	Loop 2 Control Ch2 O/P
A	Alarm 1 O/P
B	Alarm 2 O/P
C	Alarm 3 O/P
D	Alarm 4 O/P
1	Program Event 1
2	Program Event 2
3	Program Event 3
4	Program Event 4
5	Program Event 5
6	Program Event 6
7	Program Event 7
8	Program Event 8

Rear Terminals

3504

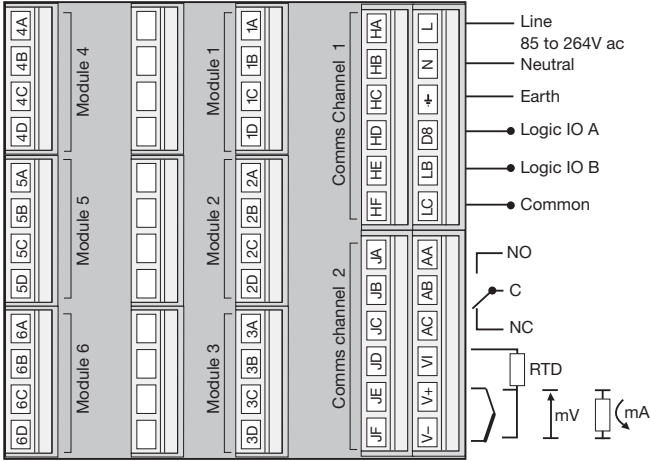

3508

